



**THIN-FILM PHOTOVOLTAIC MODULE
INSTALLATION GUIDE**

THE POWER OF ASTRONERGY



ASTRONERGY

A **CHNT** COMPANY

THIN-FILM PHOTOVOLTAIC MODULE INSTALLATION GUIDE

1. Introduction

2. Warning

3. Product Information

- 3.1 *Electrical Characteristics*
- 3.2 *Physical specifications*
- 3.3 *Module parts list*

4. Work Safety Introduction

5. Mechanical Installation

- 5.1 *Installation Condition*
- 5.2 *Installation Methods*

6. Electrical Installation

7. Maintenance

1. Introduction

This document provides detail instruction and valuable safety information regarding installation, electrical connection and maintenance of ASTRONERGY Thin Film Photovoltaic (TFPV) modules. Before installing a Thin Film photovoltaic system, the installer should become familiar with the mechanical and electrical requirement. All instructions should be read and understood before attempting to install. There are three ways of installing, short rail, CAT (Clamp and Adhesive tapes) and long rail. The installer should conform to all the safety precautions in the guide when installing the module. Keep this guide in a safe place for further reference. (All the instructions comply with UL regulations as well as CSA regulations)

2. Warning

This Photovoltaic Module produces electricity when exposed to the sun or other light source. For your safety and the safety of others, please read the entire safety and installation instruction manual carefully prior to product installation. Also, carefully read the module data sheet provided with this product. Determine local permits, installation and inspection requirements before installing module(s). The manufacturer assumes no liability for damages incurred due to non-compliance of these instructions. Please also observe the instructions for the other components which make up the total PV system.

3. Product Information

3.1 Electrical Characteristics

Table1: electrical characteristics

Pmax(W)	Nominal				Initial	
	Vmp(V)	Imp(A)	Voc(V)	Isc(A)	Voc(V)	Isc(A)
115	53.56	2.147	70.08	2.572	70.08	2.679
120	54.69	2.194	70.50	2.619	70.50	2.728
125	56.07	2.229	70.50	2.642	70.50	2.752
130	57.41	2.265	70.92	2.665	70.92	2.777
135	58.40	2.311	71.33	2.750	71.33	2.864
The electrical performance relates to standard test conditions[STC]						
Maximum over-current protection rating:6A						

The module electrical ratings are measured under Standard Test Conditions (STC) of 1kW/m² irradiance with AM 1.5 spectrum and a cell temperature of 25°C . ASTRONERGY modules deliver specific electrical characteristics as shown above.

A photovoltaic module may produce more current and/or voltage than reported at STC. Sunny, cool weather and reflection from snow or water can increase current and power output. Therefore, the values of Isc and Voc marked on the module should be multiplied by a factor of 1.25 when determining component voltage ratings, conductor amperage, fuse sizes, and size of controls connected to PV output.

3.2 Physical specifications

Table 2: physical specifications

Module type	Tandem junction	
Cell type	Amorphous/microcrystalline Silicon	
Junction type	P-i-N	
Encapsulation	PVB	
Superstrate	3.2mm float glass	
Substrate	3.2mm tempered glass	
Connector	MC4 compatible connector	
J-Box IP rating	IP65	
Cable length	Min 750mm	
Max load	30lb/ft ²	
Cable cross area	14AWG	
Bypass diode	Type	10A10
	Max current	10A
	Max voltage	1000V
Dimensions	Length(mm)	1300+0/-1
	Width(mm)	1100+0/-1
	Thickness(mm)	6.9mm (without junction box)
Weight	26.5Kg(short rail);25.6Kg(CAT); 28.5kg(Long rail)	
Max system voltage	1000VDC	

3.3 Module parts list

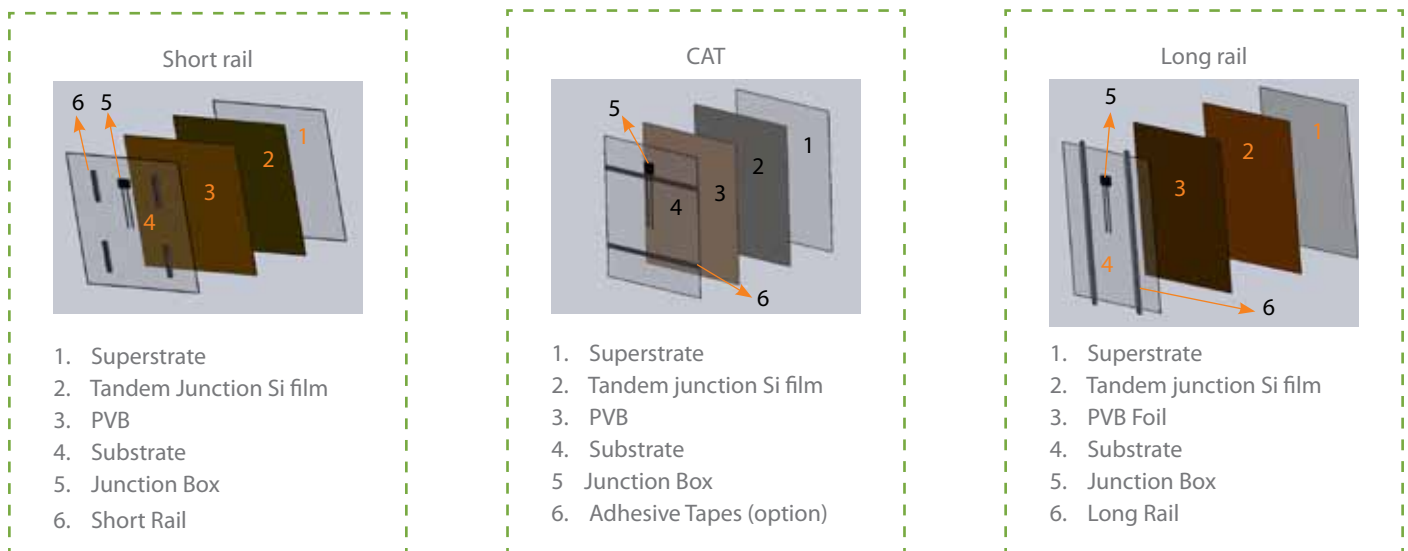

Figure1 Part list of Astronergy TF PV module

4. Work Safety Introduction

- Installing solar photovoltaic systems may require specialized knowledge and appropriate technical skills. Therefore installation should be performed only by qualified person.
- The installer should assume the risk of all injury that might occur during installation, for example, the risk of electric shock.
- One individual module may generate DC voltages greater than 70 volts when exposed to direct sunlight. Contact with a DC voltage of 70 volts or more is potentially hazardous.
- When disconnecting wires connected to a module that is exposed to sunlight, an electric arc may be resulted. Such arcs may cause burns, may start fires and may otherwise create problems. Therefore be extremely careful!
- Keep children well away from the system while transporting and installing mechanical and electrical components.
- Completely cover the module with an opaque material during installation to keep electricity from being generated.
- Do not wear metallic rings, watchbands, ear, nose, lip rings or other metallic devices while installing or troubleshooting photovoltaic systems.
- Use only insulated tools that are approved for working on electrical installations.
- Abide with the safety regulations for all other components used in the system, including wiring and cables, connectors, charging regulations, inverters, storage batteries and rechargeable batteries, etc.
- Do not attempt to disassemble the module, and do not remove any attached nameplates or components!
- Do not use mirrors or other magnifiers to artificially concentrate sunlight on the module!
- When installing the system, abide with all local, regional and national statutory regulations. Obtain a building permit where necessary.

5. 5. Mechanical Installation

5.1 Installation Condition

- Always observe the instructions and safety precautions for the module to be installed.
 1. Do not lift the module by grasping the module's junction box or electrical leads.
 2. Do not drop modules or allow objects to fall on modules.
 3. To avoid the breakage of the glass of the module, do not place any heavy objects on the module.
 4. Do not set the module down hard on any surface.
 5. Inappropriate transport and installation may break the glass of the module.
 6. Avoid any sharp objects (knife, rock etc) scratching both surface of the module.
- The module must be facing true south in northern latitudes and true north in southern latitudes.
- For detailed information on the best elevation tilt angle for the installation, refer to standard solar photovoltaic installation guides or a reputable solar installer or systems integrator.
- The module should not be shaded at any time of the day.
- Do not use module near equipment or in locations where flammable gases can be generated or collected. No attempt must be made to drill holes in the glass surface of the module. To do so will void the warranty.

- Modules must be securely attached to the mounting structure.
- PV modules are exposed to a wide range of mechanical conditions, so that surface stress may appear. Due to the different thermal coefficient of glass and metal structures, thermal stress can occur as a result of the module's outdoor exposure. DIN 1055 sets basics for the planning of a structural framework regarding building structures which must be taken into account.
- The recommended standoff height is 20cm.

5.2 Installation Methods

The following precautionary steps are recommended when mounting the module to the supporting structure.

1. The mounting assembly and the undercarriage must be appropriately dimensioned and adapted to the in-situ environmental conditions so that the admitted maximum bending/deformation is not exceeded one one-hundredth of the edge length of the module ($L/100$) (13 mm or 11 mm, respectively). No buckling/twisting of more than 30 mm across the module diagonal should be allowed.
2. Modules must be stead-fastened and in a durable elastic bedding. All direct contact of the glass/solar module with metal parts of the substructure must be prevented.
3. The module should be operated under stress- and force-free conditions.
4. Accumulation of water at the solar module must be prevented; as it might cause corrosion on the panels and on the adhesive bonding (PVB foil between front and back glass) and can cause glass blinding and impairment to the adhesive bonding.
5. Dimensioning the undercarriage, particular care should be taken of the various thermal coefficients for the used material.
6. Observe the specified fixation points at the approved mounting assemblies (tightening torque for screws, positions of the drilled holes).

5.2.1 Installation Method with short rails

Figure 2 shows one of the recommended mounting configurations of Astronergy TFPV modules with rail. As shown in the figure 2 the modules are supported by a structure consisting of the tilted beam, the vertical support and the horizontal beam. The module is secured to the structure by four mounting bolts, two on each of the supporting rails which are securely attached to the module by silicone adhesive. The details of mounting of module to the supporting structure are shown in Figure 3. A T-head M8 bolt with a bracket is used to fasten the rail to the horizontal beam. The recommended distance from each mounting point to the nearest end of the rail is 150 ± 2 mm (Middle of the short rail). The nuts should be tightened with a recommended torque wrench of $35 \text{ N}\cdot\text{m}$.

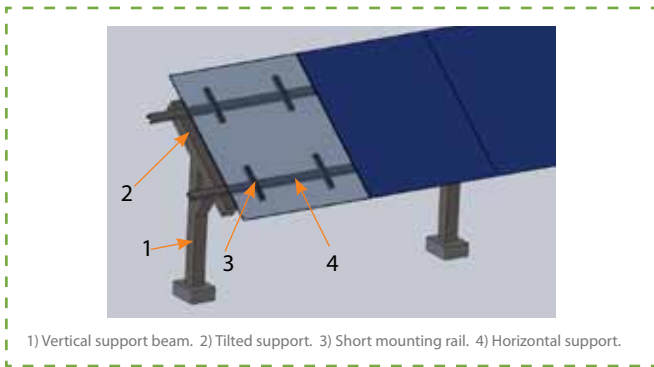

Figure 2 Mounting configuration

5.2.2 Installation Method with long rails

Figure 4 shows one of the recommended mounting configurations of Astronergy TFPV modules with long rail, but other mounting options are also possible. The module is secured to the crossbeam by four mounting bolts, two on each of the supporting rails which are securely attached to the module by silicone adhesive. The crossbeam is mounted to the pedestal of rooftop by bridge piece. The details of mounting of module to the supporting structure are shown in Figure 5. A T-head M8 bolt with a bracket is used to fasten the rail to the horizontal beam. The nuts should be tightened with a recommended torque wrench to 35 N-m. The distance between two paralleled purlins should be no less than 1270mm. The length of the rail which is between two oblong holes is 1330mm.

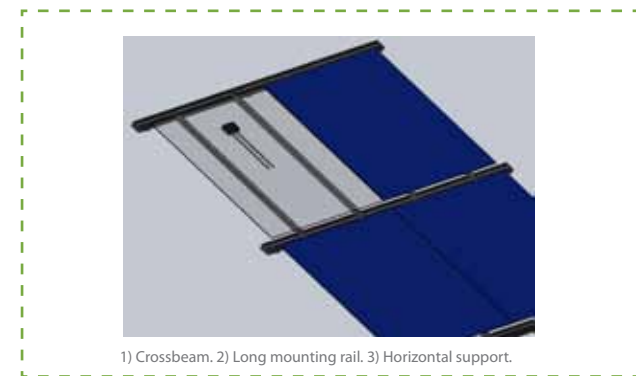

Figure 4: Mounting configuration

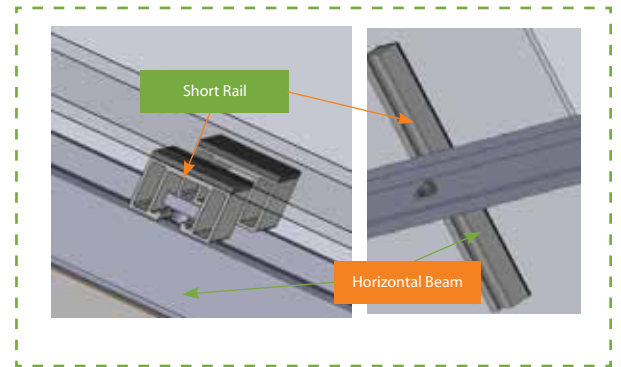

Figure 3 one of the four mounting points viewed from different direction, the module is secured to the horizontal beam by four M8 T-head bolts and nuts with spring

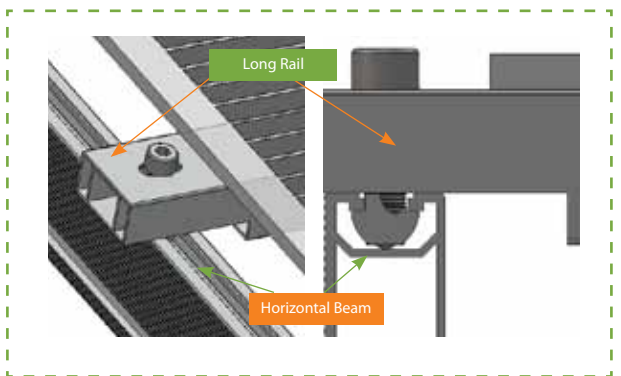

Figure 5: One of the four mounting points viewed from different direction, the module is secured to the horizontal beam by four M8 T-head bolts and nuts with spring shims.

5.2.3 Installation Method with CAT

Mounting condition

1. Requirements of adhesion interface :

- a) The tape could be adhered to interface of high surface energy such as glass, metal, etc. If the tape is applied to the interface of low surface energy, please consult supplier for mounting plan ;
- b) No visual dirt, remains of oil, solvents, water, etc on the adhesion surface :
- c) Materials adhered to adhesion surface must not fall off or strip from parent materials.

2. Requirements of purlins adhered to the tape :
 - a) Width: $\geq 40\text{mm}$
 - b) Distance between 2 purlins= $720\text{mm}\pm 5\text{mm}$
 - c) Surface flatness: $1100*40:1.5$
 - d) Co-planarity of adjacent purlins to any 1100mm-long side: $\leq 3\text{mm}$
 - e) No breakpoint in purlins adhered to tape ;
3. Environmental conditions :
 - a) Suitable operation temperature: $0-35$:
 - b) No operation in dust-raising and rainy days :
4. Tape requirement :
 - a) Supplier: LOHMANN GMBH&CO KG; type: Duplocoll 20089
 - b) width: 40mm
 - c) thickness: 1.3mm

5.2.3.1 Installation Method 1:

- 1) Stick 2 adhesive tapes along the direction of the purlins, the length of each tape should be 1100mm.

Note: Make sure the tapes are at an equal distance from the both edges of the rail. (As shown in the figure 6)

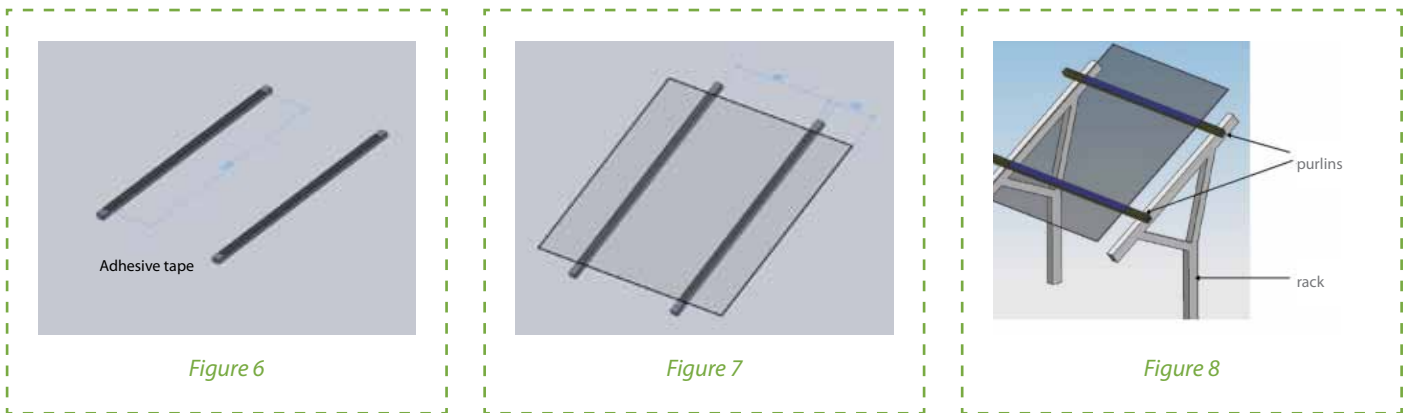

- 2) Carefully mount the module directly on the purlins.

Note: Make sure that the tapes are in good contact with the purlins and the rail are at the equal distance from the short edge of glass, and must ensure that the rail parallel to the short edge of glass. (As shown in the figure 7)

- 3) Carefully mount the module directly on the rack.

Note: Make sure that the rails are at the equal distance from the rack. (As shown in the figure 8)

- 4) Place Z- clamps along the long side of the modules.

Note: Clamps should be along the long side of the module.

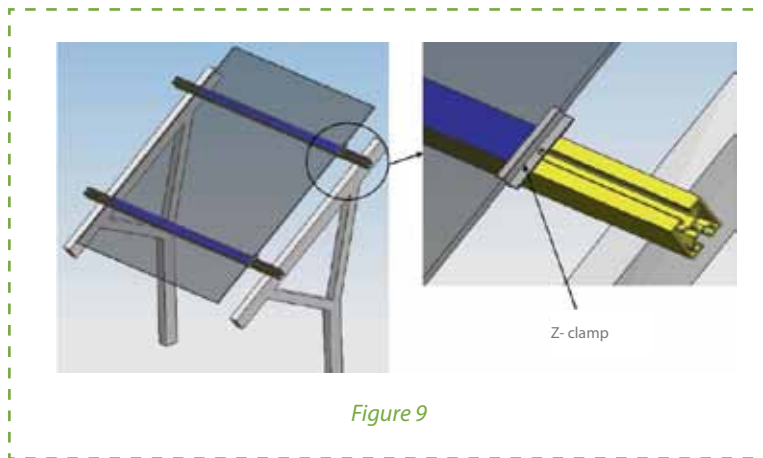

- 5) Slide bolt along the groove of the purlins to the position where it is to be installed.

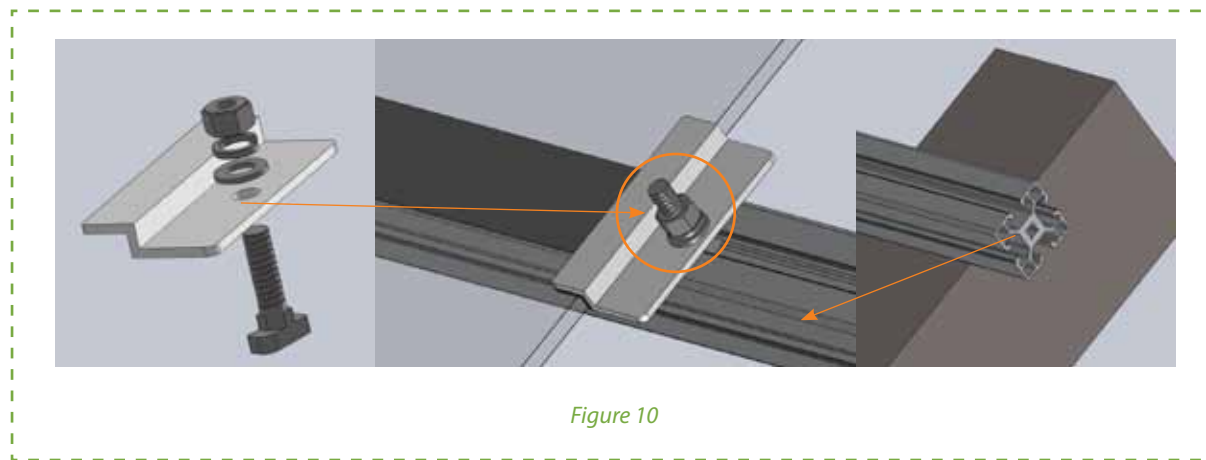

- 6) Place the Z- clamp through the bolt, and insert rubber strip (the rubber strip should be weather proof material such as EPDM) between the clamp and the module. Then attach washer, spring washer and nut, through the bolt.

Note: use wrench to tighten the nut. The recommended torque range is 10-15N*m. (As shown in figure 11). The recommended dimensions of the clamp: A and D are the rubber thickness, B is the rubber width, and C is the height of clamp.

A=1.5~2mm

B=14±0.23mm

C=8±0.2mm

D=1.5~2mm

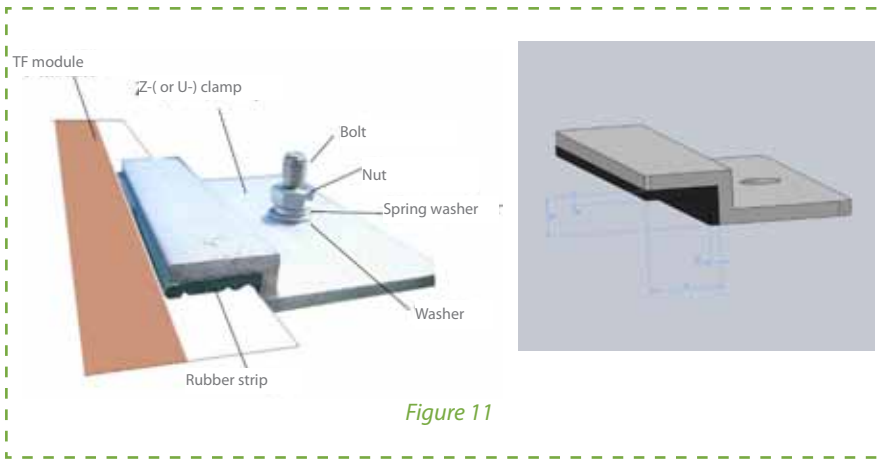

Figure 11

5.2.3.2 Installation Method 2

- 1) Stick 2 adhesive tapes along the direction of the short edge of the module, the length of each tape should be 1100mm.
 Note: Make sure the tapes are at an equal distance from the both edges of the module and in good contact with the glass, specially ensure that the tapes parallel to the short edge of module. (As shown in figure 12)

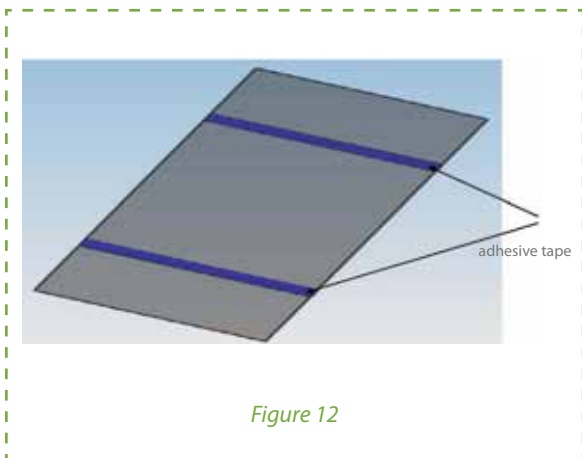

Figure 12

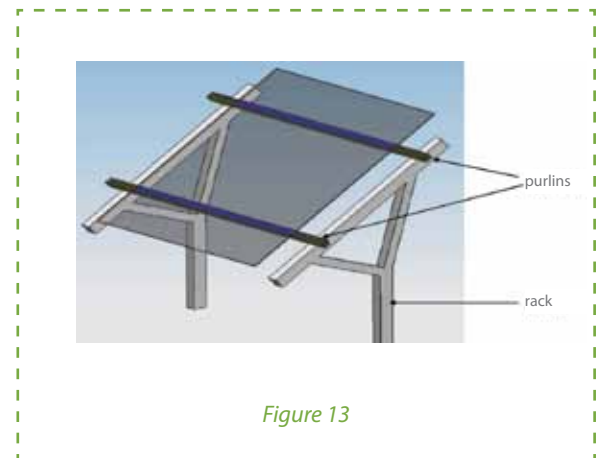

Figure 13

- 2) Carefully mount the module directly on the purlins. (Or purlins had been previously installed on the rack according to customer's request)

Note: Make sure that the tapes are in good contact with the purlins. (As shown in figure 13)

- 3) - 6) Same as method 1.

6. Electrical Installation

- Do not use modules of different configurations in the same system.
- The module is supplied with connectors for the electrical connections of the system.
- Connector
 1. Modules may be connected in series and/or parallel to achieve the desired electrical output as long as certain conditions are met. The definitive number of parallel connected modules depends on the plant topology (Inverter sizing according to known practice, protection means, etc). If there are no any particular voltages protections, no more than 8 modules or strings are to be series connected. And also the maximum reverse current is 6A. Blocking diodes or fuses at the head of the strings shall be used for reverse current protection when more than 3 strings are connected in parallel.
 2. Important! For optimal performance, modules using CAT installation method must only be used in configurations where the negative polarity of the PV module is connected to ground (use of inverters with transformers with negative grounding). Failure to comply with this requirement will reduce the performance of the system and invalidate warranty for the modules.
 3. Only connect series solar power modules of the same type and power category. It is not necessary to open the connector box with cables connected at the factory for electrical switching of the solar power modules!
 4. The plugs are marked with the respective polarity (see Figure 14). The MINUS pole is minus-coded; the PLUS pole is plus-coded.



5. If additional cables are needed, only use appropriate cables.
6. Be absolutely sure to observe the modules' polarity. Reverse polarity might cause destruction of the protective diodes!

7. Maintenance

- We recommend the following maintenance in order to ensure optimum performance of the module:
 1. Clean the glass surface of the module as necessary. Always use water and a soft sponge or cloth for cleaning. A mild, non abrasive cleaning agent can be used to remove stubborn dirt.
 2. Check the electrical and mechanical connections every six month to verify that they are clean, secure and undamaged.
- If any problem arises, have them investigated by a competent specialist.
- Observe the maintenance instructions for all components used in the system, such as support rails, charging regulators, inverters, batteries etc.



CORPORATE HEADQUARTERS

Chint Solar (ZheJiang) Co., Ltd.
 1335 Bin'an Road, Binjiang District
 Hangzhou, Zhejiang Province, 310053
 China
 Tel: + 86 571 5603 1888
 Fax: + 86 571 5603 2383

MANUFACTURING PLANTS

Hangzhou, Shanghai & Wenzhou

BRANCH OFFICES

Spain

Chint Solar Hispania S.L.
 Paseo de Gracia, 78, 2-2A
 08008 Barcelona, Spain
 Tel: + 34 9346 73778
 Fax: + 34 9346 73789

Germany

Astronergy GmbH
 Karlstr. 8
 88212 Ravensburg, Germany
 Tel: + 49 (0)751 295096-0
 Fax: + 49 (0)751 295096-39

North America

Astronergy Solar Inc
 377 Swift Avenue
 South San Francisco, CA 94080
 USA
 Tel: + 1 650 827 9810
 Fax: + 1 650 392 2778

Japan

KoyoAstro Co., Ltd.
 Higashi 1-5-6, Chuo-ku,
 Tokyo 103-0004, Japan
 Tel: + 03 3866 6113
 Fax: + 03 3866 6115

Korea

Astronergy Solar Korea
 Misung Bldg 3F,
 91-5 Banpo-dong, Seocho-gu,
 Seoul, Korea
 Tel: + 82 (0)2 2226 3911
 Fax: + 82 (0)2 2226 3910

Thailand

Astronergy Solar Korea (Thailand) Co.,
 Ltd.
 184/88 Forum Tower 18FL
 Ratchadapisek Rd., Huay-Kwang,
 Bangkok 10320 Thailand
 Tel: + 662 645 4155
 Fax: + 662 245 3185